

CP2000-CT2

Low-Volume Countertop Sparkling & Chilled Still Water Dispenser







Low-volume countertop beverage dispensing unit that provides cold-carbonated sparkling water and chilled still water. Self-contained refrigeration with European design stainless steel exterior. Suitable for office, hotel suites, wineries, and residential.

Features

- Cold carbonation at up to 50, 12oz drinks/hour (<40°F)
- Dual-water dispensing (sparkling + chilled still)
- High-efficiency self-contained refrigeration
- Durable, 304 brushed stainless steel exterior*
- Cup fill station with 9" clearance

Accessories

- Water filter system (required):
 - CR-14FC: Single filter system, compact fibredyne filters, reduce chlorine, taste, odor, color while retaining the good minerals that are essential for bottle quality tasting water, 18"H x 8"W, 2.5 gpm, 15,000 gal, TOC & ½ micron filtration 
 - CR-14FCP: Single filter system with prefilter, compact fibredyne filters, reduce chlorine, taste, odor, color and organic chemicals while providing exceptional sediment reduction with resistance to premature plugging, 15"H x 14"W, 2.5 gpm, 15,000 gal, TOC & ½ micron filtration
- Install kit (required):
 - CR-KIT-CPCT: Installation kit for CP2000-CT countertop units, includes water pressure reducer valve, fittings, and extra tubing to install the filter systems and countertop unit 
- Dispense levers:
 - CR-SDL-1: Single sanitary dispense lever that attaches to a self-closing faucet on unit. 1 per faucet. Great for self-service hands-free dispensing applications 
- CO2 regulators:
 - CR-PC160-14FCV: Primary high pressure CO2 regulator for CO2 tank 
 - CR-S115-14FCV: Secondary CO2 regulator for bulk CO2 supply
- Wall brackets:
 - CR-CWB1: Single CO2 gas cylinder wall bracket 
 - CR-CWB2: Twin CO2 gas cylinder wall bracket



CP2000-CT2

Low-Volume Countertop Sparkling & Chilled Still Water Dispenser



Scan for more resources!

Line Drawings

Front View

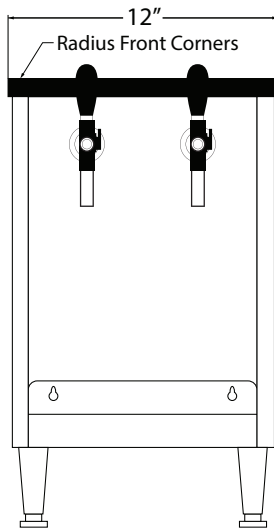

Side View

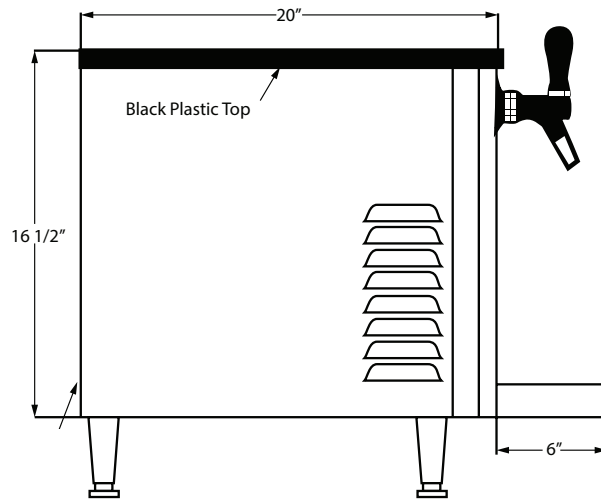

- 3/8" Water inlet push in fitting at back of machine
- 7' Over flow drain hose
- 7' CO2 hose 1/4" flare fitting
- 9' Electrical cord NEMA 5-15
- 4.0" - 5.5" adjustable legs
- Air intake on side panels, exhausts out rear
- Allow for 6" rear & side clearance for air flow

Capacity	50, 12oz drinks/hour (<40°F)
Refrigerant	R290
Width	12"
Depth	26"
Height	20.5"
Cup fill clearance	9"
Compressor	1/9 H.P.
Carbonator	1 GPM

Operating temp	40°F-100°F
Electrical	120v - 3.62 Amps
Water bath	2.5 gal
Ice bank	6 lbs
Weight	80 lbs