

CP-JR-CT1-SWF-K

Low-Volume Compact Countertop Chilled Still Water Dispenser



Low-volume compact countertop beverage dispensing unit that provides chilled still water. Self-contained refrigeration with European design stainless steel exterior. Suitable for office, hotel suites, wineries, and residential.

Features

- Up to 40, 8oz drinks/hour (<45°F)
- Chilled still water dispensing
- Self-contained refrigeration
- Durable, 304 brushed stainless steel exterior
- Cup fill station with 8" clearance
- Installation kit included

Accessories

- Water filter replacement:
 - 2FC: Compact fibredyne cartridge for CP-JR models
 - 2FC-P: Compact fibredyne cartridge, 1.5 gpm 1,000 gal capacity. Certified PFOA/PFOs and lead-reduction filter, TOC and 0.5 micron



Complete installation kit (included with purchase of unit):

The unit comes standard with a filter system built on. Installation kit comes complete with a leak block sensor, hose, and angle stop fittings.

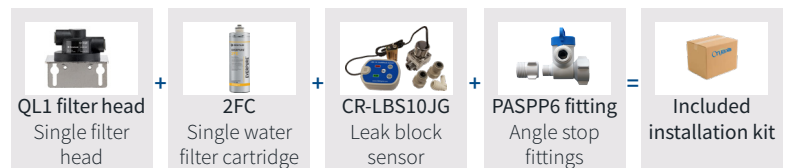

R290



CP-JR-CT1-SWF-K

Low-Volume Compact Countertop Chilled Still Water Dispenser



Scan for more resources!

Line Drawings

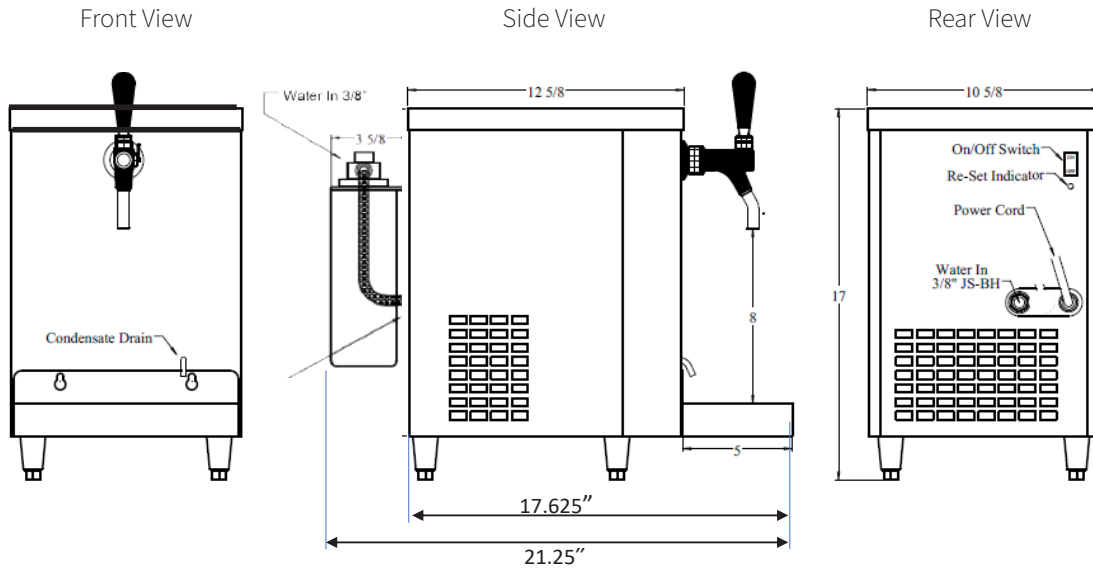

- 3/8" Water inlet push in fitting at back of machine
- 9' Electrical cord NEMA 5-15
- 2.5" legs
- Pre-mounted water filter system with 2FC quick change cartridge
- Air intake on side panels, exhausts out rear
- Allow for 6" rear & side clearance for air flow
- Condensate drain into drip pan

Capacity	40, 8oz drinks/hour (<45°F)
Refrigerant	R290
Width	10.625"
Depth	21.25"
Height	17"
Cup fill clearance	8"

Compressor	1/9 H.P.
Operating temp	40°F-100°F
Electrical	120v - 1.7 Amps
Water bath	1.5 gal
Ice bank	3 lbs
Weight	60 lbs