

## Serenity-X3

Residential remote system

Specification Sheet

R290



Scan for more resources!

### Key Features

#### Chiller

- 10, 8oz drinks per hour at <40°F
- 10.5"W x 14.375"D x 18.125"H
- Weight: 60 lbs
- Refrigerant: R290
- Compressor: 1/9 H.P.
- Operating temperature range: 40°F-100°F
- Electrical: 120v - 2.9 Amps
- Water bath: 1 gallons
- Ice bank: 3 lbs

#### Tower

- Bottle filling clearance: 9"-10"
- 12.5"H
- Weight: 8 lbs

Project:



Low volume sparkling water, chilled still water, and ambient still water on tap

Self-contained refrigeration system

CR-X3PB-COMP tower and CP-JR-UC-BH remote chiller

For residential applications only

### Product Overview

- Ideal for over sink mount
- 3 Push-to-dispense buttons and swiveling nozzle arm
- Adjustable flow rate
- Installation kit included
- Bulkhead fittings for easy hookup to faucet
- Chiller and tower should be positioned within 4' of each other

# Line Drawings

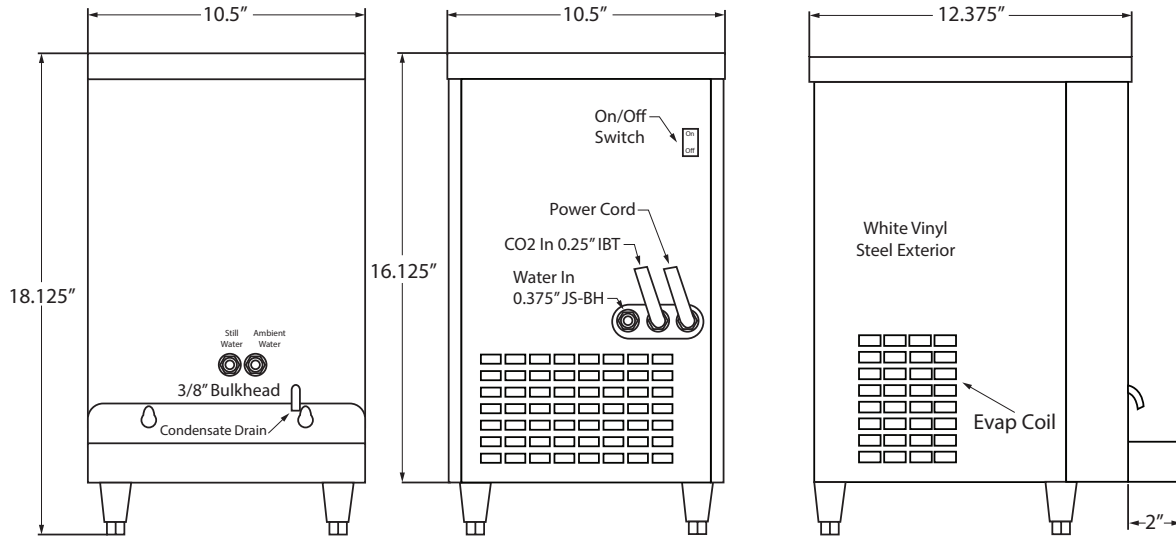

- 3/8" Water inlet connector
- 7' Over flow drain hose
- 7' CO2 hose 1/4" flare fitting
- 8' Electrical cord NEMA 5-15
- 2" legs
- Air intake at rear with air filter
- Allow for 6" rear & side clearance around unit for air flow

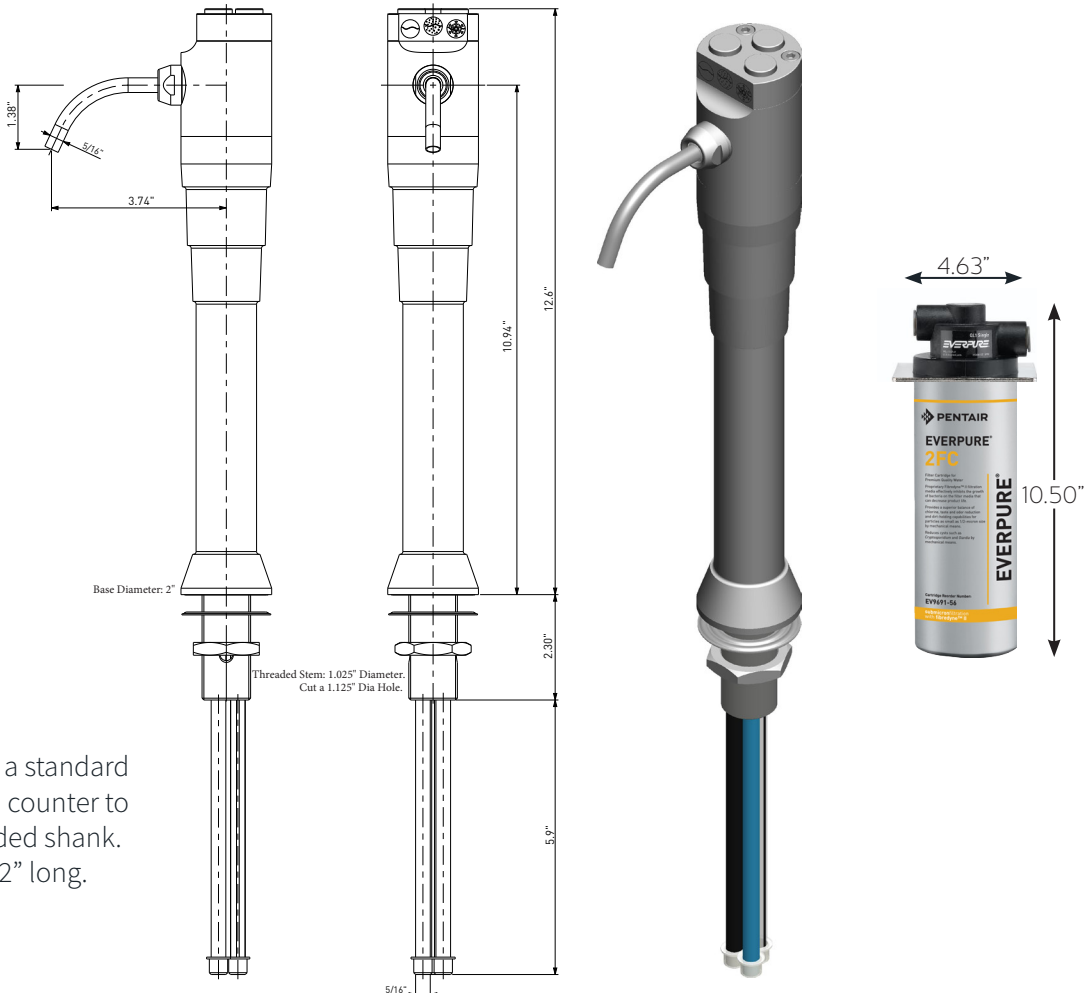

Install: Requires a standard 7/8" sink hole in counter to clear 3/4" threaded shank. Shank length is 2" long.

## Complete Installation Kit

Included with purchase of unit

Installation kit comes complete with a water filter system, water pressure reducer valve, CO2 regulator, leak block sensor, hose, and angle stop fittings.



## Accessories

- 2FC Replacement filter**  
Replacement water filter. Compact fibredyne cartridge for CP-JR models



- 2FC-P Replacement Water Filter**  
Compact fibredyne cartridge, 1.5 gpm 1,000 gal capacity. Certified PFOA/PFOS and lead-reduction filter, TOC and 0.5 Micron



- CR-CWB1**  
Cylinder safety restraint wall bracket
- Customer supplied CO2 tank required**



- DP-CT**  
Stainless countertop mount drain pan configured with a 1/2" drain tube for direct plumbing



- DP-CT-LD**  
Drip pan, less drain, with rubber feet



Looking for a different style faucet tower?  
Contact us about configuring this system with the CBR-V2C-MINI-SSX tower.

