

CR-UCM1

Remote Sparkling & Chilled Still Water Chiller



*CR-UCM1 shown with optional CR-ABUCM air baffle

Commercial remote/undercounter chiller unit that provides cold-carbonated sparkling water and chilled still water. Self-contained refrigeration designed for back-of-house or undercounter installation up to 35' from draft tower. Suitable for high-volume service stations and hospitality applications.

Features

- Cold carbonation at up to 50 liters/hour (<40°F)
- Sparkling and chilled still water
- High-efficiency self-contained refrigeration
- Built-in re-circulatory pump allows for an installation distance up to 35' between tower and chiller
- 1 Stainless steel water coil (sparkling water) & 1 copper coil (chilled still water)
- Multi-tower and custom configurations available



Accessories

- Water filter system (required):
 - CR-24FC: Twin filter system, compact fibredyne filters, reduce chlorine, taste, odor, color while retaining the good minerals that are essential for bottle quality tasting water, 19"H x 17"W, 5 gpm, 30,000 gal, TOC & ½ micron filtration
 - CR-24FCP: Twin filter system with prefilter, compact fibredyne filters, reduce chlorine, taste, odor, color and organic chemicals while providing exceptional sediment reduction with resistance to premature plugging, 19.25"H x 21.75"W, 5 gpm, 30,000 gal, TOC & ½ micron filtration
- Install kit (required):
 - CR-KIT-UCM: Installation Kit for remote chiller units, UCM1 & UCM2, includes: 5ft of CR-4L38 insulated trunkline, LBS10JG Leak Block sensor, fittings, clamps, tubing and insulation to install the CR-24FC filter system, CR-UCM# and CBR tower together
- CO2 regulators:
 - CR-PC160-14FCV: Primary high pressure CO2 regulator for CO2 tank
 - CR-S115-14FCV: Secondary CO2 regulator for bulk CO2 supply
- Wall brackets:
 - CR-CWB1: Single CO2 gas cylinder wall bracket
 - CR-CWB2: Twin CO2 gas cylinder wall bracket
 - CR-WMB1: Wall mount bracket for CR-UCM1
- Ventilation:
 - CR-ABUCM: Air baffle recommended anytime a remote chiller is installed in a cabinet
 - CR-TFB1: Thermostatic fan box recommended anytime a remote chiller is installed in a cabinet
- Trunkline:
 - CR-4L38: Four-line insulated trunkline 3/8" two-product, two recirculating 5' is included in remote chiller install kit
- Use with CBR-V2 series draft tower and drain pan



CR-UCM1

Remote Sparkling & Chilled Still Water Chiller



Scan for more resources!

Line Drawings

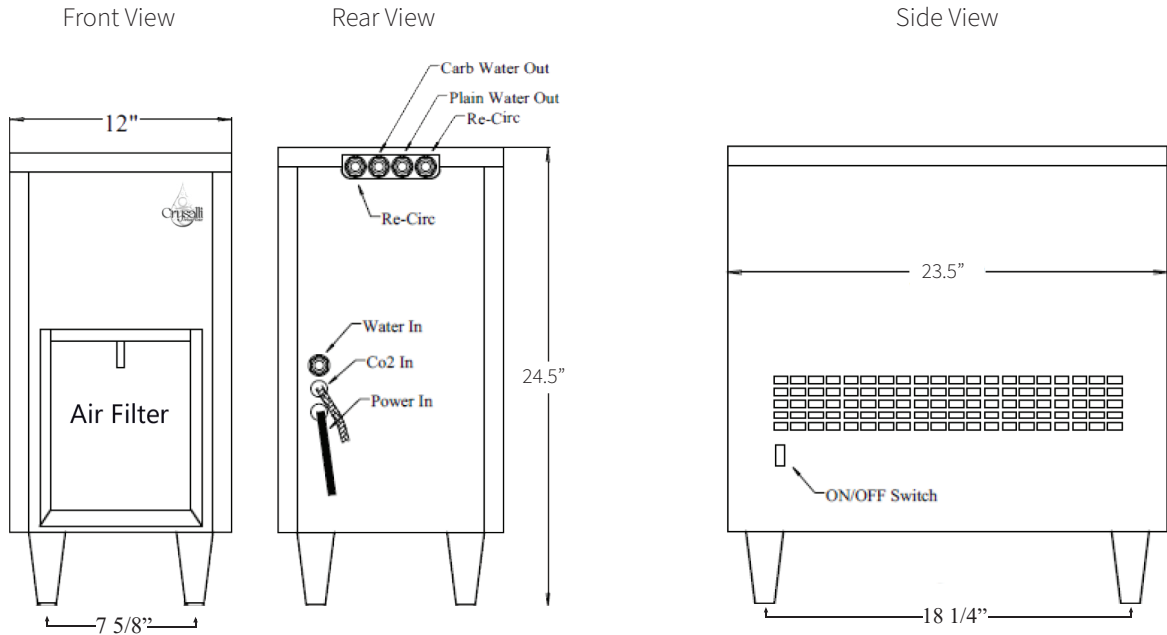

- 3/8" Water inlet push in fitting at back of unit
- 7' Over flow drain hose
- 7' CO2 hose 1/4" flare fitting
- 9' Electrical cord NEMA 5-15
- Trunkline connections at the top, back of unit
- CO2, drain & electrical out at back side
- Ensure well-ventilated space or cabinet
- Air intake at front with air filter
- Allow for 6" side clearance for air flow out
- Allow for 8" of clearance above unit for service and water bath access
- Allow for 3" of rear clearance for connections

Capacity	50 liters/hour (<40°F)
Refrigerant	R290
Width	12"
Depth	23.5"
Height	24.5"
Compressor	1/5 H.P.
Carbonator	1/3 H.P.

Operating temp	40°F-100°F
Electrical	120v - 10.3 Amps
BTU Output	~2,200 BTU/hr
Water bath	4 gal
Ice bank	9.5 lbs
Weight	115 lbs