



Install Guide

CP2000-R-UC-BH Sparkling & Still Undercounter Chiller System With CBR Series Draft Tower



















Register your
product online:



CR-KIT-CPUC Install Kit

Ordered Separately

Install Kit for CP2000-UC to CBR-V2 Tower

QTY	Description	Part Number	Usage
1	 3/8 Tube x 9/26-24 Female Adapter	PSEI6012U9	Quick connect fitting adaptor to an anglestop
2	 1/2" Tube to 3/4" NPT	PSEI02026	Adaptor reducers for filter system inlet and outlet
2	 5/8" (1/2") Stem to 3/8" tube	PP062012W	Adaptor reducers for filter system inlet and outlet
5	 JG 90 elbow 3/8" smooth to 3/8"	PP221212W	For trunkline outlet of unit and water inlet
2	 JG 3/8" mpt to 3/8" tube	PI011223S	For CR-14FC water filter head, inlet and outlet
2	 JG reducer, 3/8" stem to 1/4" tube	PP061208W	Reducing union, to connect product hoses to tower fittings
2	 JG 90 1/4" smooth to 1/4"	PP220808W	Optional product water outlet connections on unit
1	 JG U shape union 3/8" to 3/8"	PIUB12S	To complete water re-circ circuit from conduit
1	 JG 3/8" to 3/8": union	PP0412W	Extra 3/8" push-in fitting union for adding water line
2	 JG 1/2" mpt to 3/8"	PI451214FS	For Shurflo Water Reg. inlet and outlet
1	 50 PSI Water Pressure Regulator	183-150-NF	Install after water filter system to regulate pressure feeding unit to 50 PSI
1	 15' Roll of Armaflex tape	1007	Insulation tape for wrapping conduit lines and tower
4	 15" Zip Ties	S-14042	For securing hose and water reg to wall
4	 JG 1/4" Locking Clips	PIC1808R	Collet locking clip for 1/4" JG fittings
15	 JG 3/8 Locking Clips	PIC1812R	Collet locking clip for 3/8" JG fittings
1	 12' Section of 3/8" OD tubing	PE-12-EI	Water inlet tubing, filter system to chiller

This Kit is designed to supply you with the fittings & parts you may need to complete the install of a CR-14FC filter system to a Crysalli Countertop CP2000-UC-BH and tower or faucet.

Reference the Crysalli Countertop system Quick Install Guide for part usage and install details.

Connections: The water inlet is the 3/8" quick connect fitting on the bottom of the chiller. Use the PP221212W.

The clear hose is the overflow drain hose.

The 1/4" white braided hose with fitting is the CO2 inlet. The CR-PC160 CO2 Regulator connects to this.

Water bath must be manually filled with water.

Always reference local plumbing codes to determine if a backflow preventer is required and to check the type/style of backflow preventer that is accepted as well as the plumbing location it needs to be placed in.

Crysalli does not include backflow preventers in the install kits because of variability in requirements.

Backflow devices should be sourced from local plumbing stores.

For questions or assistance with install contact Crysalli 510-732-0100 or your local Distributor.

CP2000-R-UC-BH

Quick Installation

Guide Instructions

1. Select a counter location for your draft tower and an undercounter location for the CP2000 chiller, making sure they are within 6' of each other (unit requires ventilation inside space it is being placed and clearance around it). Place the CP2000 unit within 6" of the water filter connection, floor sink & dedicated 120-volt electrical outlet (non-GFI preferred).
2. Locate the CR-KIT-CPUC Install Fitting Kit, the CR-14FC water filter system, the CBR draft tower, RDP drain pan and CR-PC160 CO2 regulator. Take care to not lose or misplace any of the fittings from the kits. When opening the box for the CBR draft tower, note that the faucets, faucet handles, faucet wrench and several fittings specifically for the draft tower ship loose with tower.
3. Prepare the counter for mounting the drain pan and draft tower per the cutout and hole dimensions of the models used. Set the drain pan in place and silicone seal it to the counter. Mount the tower and secure the superseal fitting to the product tubes on the tower. See pages 5, 6 & 7 for fitting info, drain pan cut out and mounting the tower.
4. Locate the 6' of CR-4L14 insulated trunkline supplied with the CR-KIT-CPUC Install kit and prep both ends by trimming the tubes and adding the appropriate fittings for connections to the chiller and tower.
5. Connect the tower and chiller. Both of these connection ends should be wrapped with the insulated foam tape completely covering all exposed hoses and fittings, to prevent sweating and heat loss and damage to the fittings.
6. Apply the fittings to the water filter system, and mount it vertically in an accessible location. Locate and attach the 50 PSI water pressure regulator on the outlet side plumbing of the filter system.
7. Unwrap the hoses and electrical cord coming out of the chiller. Make water inlet and CO2 inlet connections. Route over flow drain to floor sink. Run electrical cord to plug.
8. Fill the water bath: remove lid and fill water bath with non-filtered tap water, fill up no less than ¼" to top of white standpipe or until the water coil is completely covered. This is the vertical white tube in the water bath that is connected to the clear overflow hose.
9. Turn on the water. Check connections for leaks and flush the water filters.
10. Open CO2 by turning knob on tank. Adjust regulator to 75 PSI and check for leaks.
11. Wrap all the exposed fittings, product lines and recirculation lines of the chiller side and tower side with the insulated tape provided. This will insulate them to stay cold and prevent condensation on the lines.
12. Plug unit power cord into 120-volt outlet. Toggle the on/off rocker switch to the "on" position. Fan and compressor will turn on. Fan and compressor will automatically turn off when a complete ice bank is made and cycle on and off to maintain it.
13. Unit will take between 3 & 4 hours to make a complete ice bank.
14. Pull open the still water and sparkling water faucets to run water through the system. You will need to run the sparkling water faucet for several minutes to cycle the carbonation system before full sparkling water will dispense.
15. Once unit has built the ice bank check the carbonation of sparkling water and adjust flow rate via the faucet. You are now ready to dispense chilled still and sparkling water.

Undercounter Chiller System Start-up and Install Check List

Start-up Sequence:

- Turn water on to unit (confirm flow from faucets)
- Plug unit in and toggle on/off switch to the on position.
- Turn CO2 on at tank (carb tank may need to be bled).
- Review system operation & maintenance w/ customer.

Water Filters, CR-14FC and CR-14FCP:

- Water on. Filters flushed via the flush valve and flowing water.
- Water pressure at/through water filter system above 50 PSI and not dropping off.
- 50 PSI water pressure regulator installed in the correct direction and after the water filter system.
- All connections leak-free.

CO2:

- CO2 hose from unit: flare nut connection on end of CO2 hose tight to CR-PC160 CO2 Regulator (be sure to use nylon washer supplied with reg in fitting).
- CO2 reg connected to CO2 tank (card board/plastic washer used) tight and leak-free.
- CO2 tank full, opened all the way and set to 75 PSI.

CBR Tower:

- Faucets tight to shank and positioned vertically. Free of leaks. Customer has faucet wrench and instructed how to use it.
- Handles are screwed down tight, front facing and on the appropriate faucet.
- Sparkling water; cold, carbonated and tastes clean and pure (run a few liters of water; is carb pump cycling on and flow consistent without gassing out).
- Still Water: cold and consistent flow. Tastes clean and pure.
- Flow adjustment on faucets set and knob tightened down so flow rate appropriate and locked in.
- Connections to tower made using supplied Superseal JG fittings from kit and leak-free.
- All exposed hoses and fittings all wrapped in insulated foam tape.

Remote Chiller - Unit On:

- Unit on and plugged into a dedicated 120V outlet.
- Cabinet properly ventilated to handle BTU load of unit heat. Can fresh air draw in and hot air vent out. Unit free of obstructions around it and can vent.
- If using CR-TFB1 fan box, confirm it is in place, plugged in and cycling on and off at 90 degrees.
- Rear outlet connections for trunkline (hoses and fittings) to tower wrapped in insulated tape and leak free.
- Water inlet connection to unit leak-free and not pinched off anywhere.
- Water bath filled with non-filtered water up to the top of the white stand pipe.
- Still water: cold and consistent flow. Tastes clean and pure. Adjust flow control on faucet to needs.
- Check clearances; Unit should be able to ventilate hot air out sides and breathe fresh air in the back. Unit free of obstructions around it and can vent.
- Air filter in rear of machine is accessible.
- Water inlet connection to unit leak free and not pinched off anywhere.
- Agitator pump agitating bath water.

Undercounter Chilled Water Dispenser Quick Installation Guide

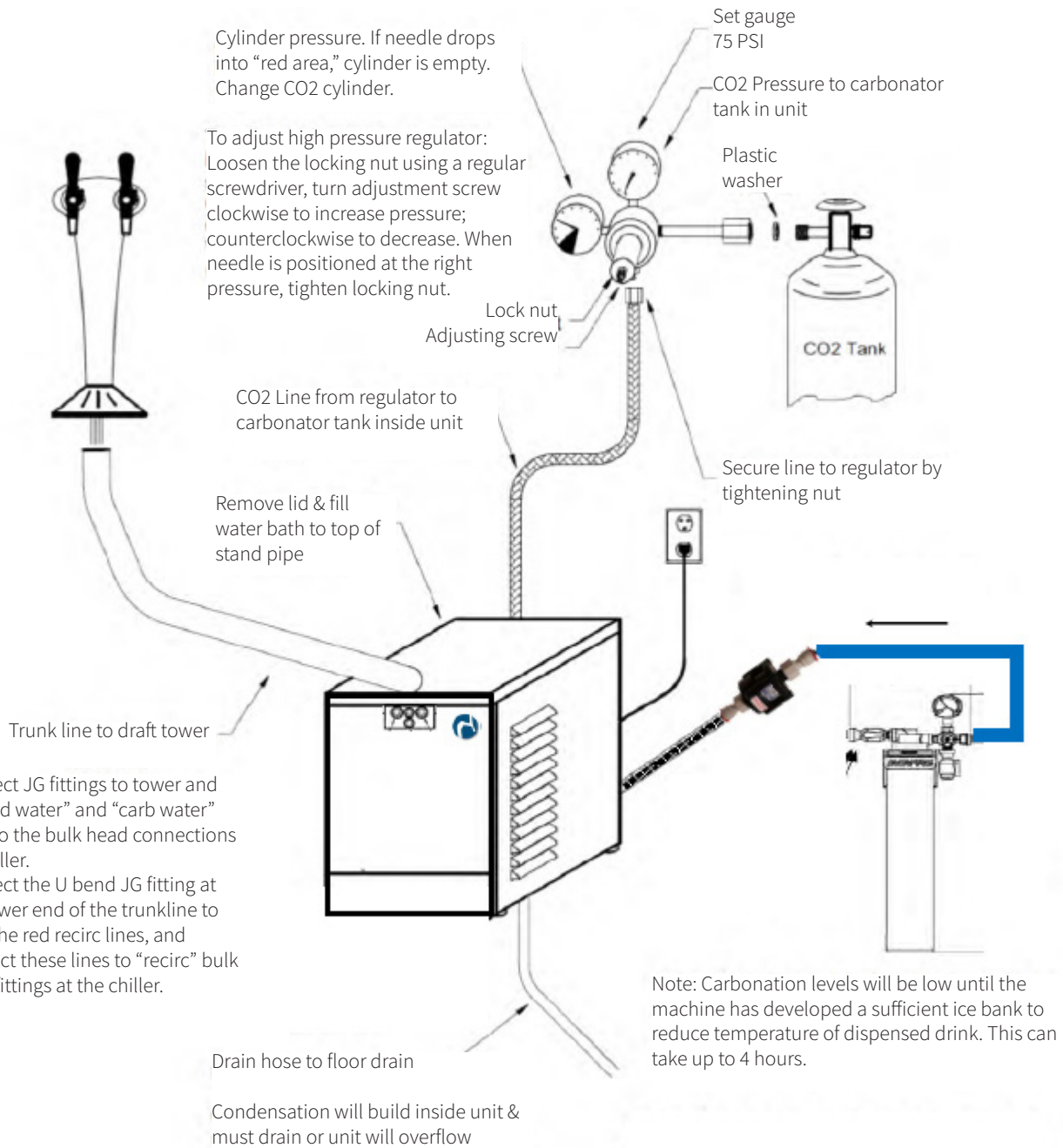

Mounting the RDP-1SSQ or RDP-3SS Recessed Drain Pan

Counter requires a square cut for drain pan section and hole cut for tower:

- CBR-V1: 1 3/8" hole
- CBR-V2: 1 1/2" hole
- CBR-V3: 1 7/8" hole
- LIT-V2C: 2" hole
- LIT-V3C: 2" hole

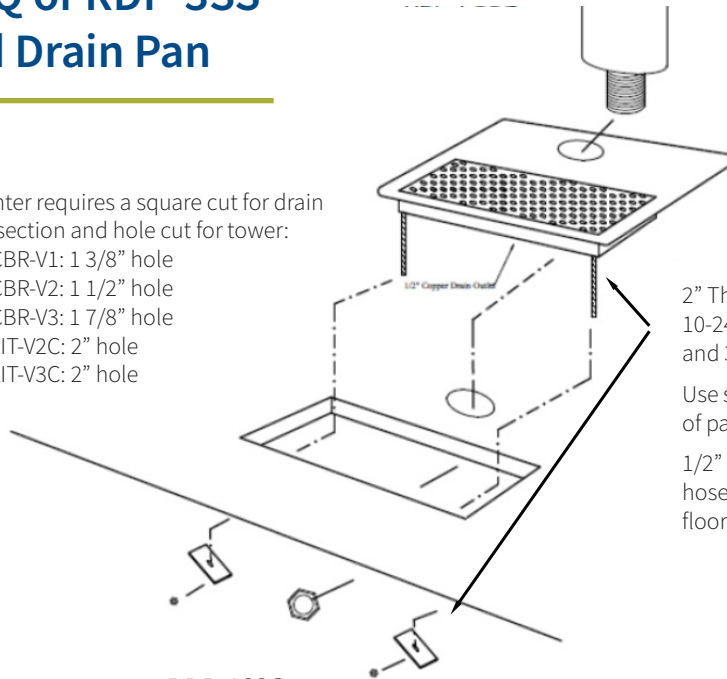

RDP-1SSQ



2" Threaded stud for mounting.
10-24 Thread with locking nut and 3"x1" SS Mounting Strip.

Use silicone on bottom and edges of pan to seal to countertop.

1/2" Drain stub, connect hose/pipe and run to floor sink.

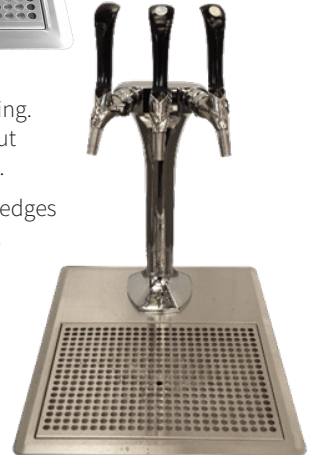

RDP-3SSQ

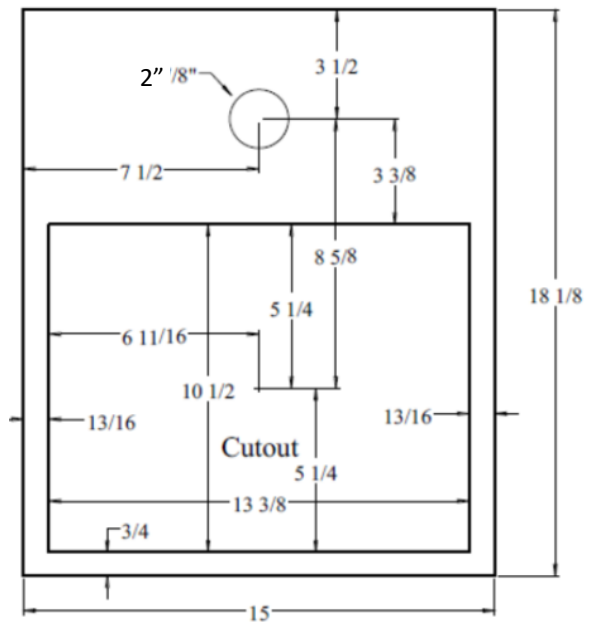
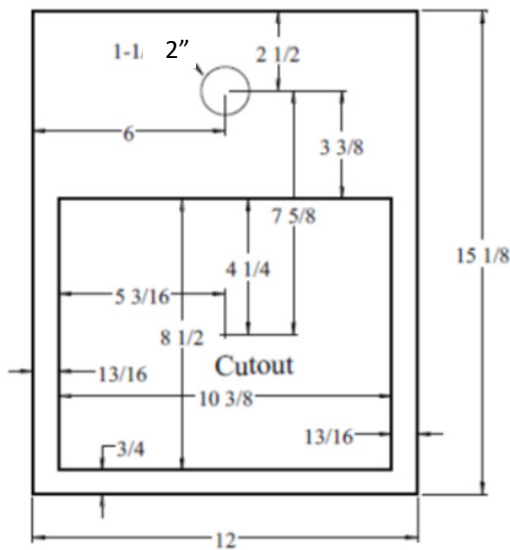

RDP-1SSQ for use with:

- CBR-V1C/W Tower
- CBR-V2C/W Tower
- LIT-V2C Tower
- CM-2-PB-SB Push Button

Specs:

- 12" x 15 1/8" Overall
- 2" Tower hole on pan
- 10 3/8" x 8 1/2" Drain pan
- 1/2" Dia copper drain stub

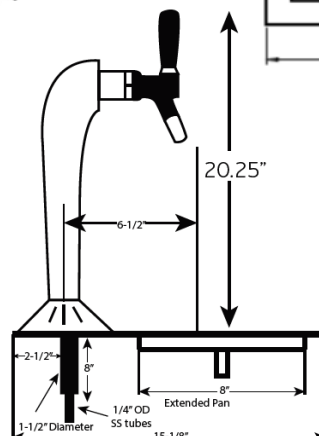

Mount and connecting the CBR towers

Step 1: Locate the box containing the tower for the system. A draft tower, such as the CBR-V2C-SSX or CBR-V3C-SSX, is packaged with the faucet bodies and handles shipped loose, a faucet wrench, a set of SI030812S superseal fittings for the 1/4" stainless steel tubes on the tower, PP221212W plug in elbow fittings and instructions.



Step 2: Insert tower into the hole in the countertop for it, thread on and tightened the set nut to secure tower. Locate grey SI030812S superseal union elbow fittings supplied with the tower (one per tube). Loosen the collet nut on the fitting to the last thread then push the fitting onto the 1/4" stainless steel tube as shown on John Guest instruction page. Tighten the collet nut all the way down to lock fitting onto SS tube (failure to tighten the collet nut

can result in a leak or the fitting slipping off). You will use the white plug-in elbow fittings to connect the product line from the trunkline to the tower. It is easiest to attach these fittings to the product tubes of the trunkline first (using the red locking clips), then connect them to the superseal fittings on the tower tubes (see "CR-4L38 Trunkline Tower End Connections" page).

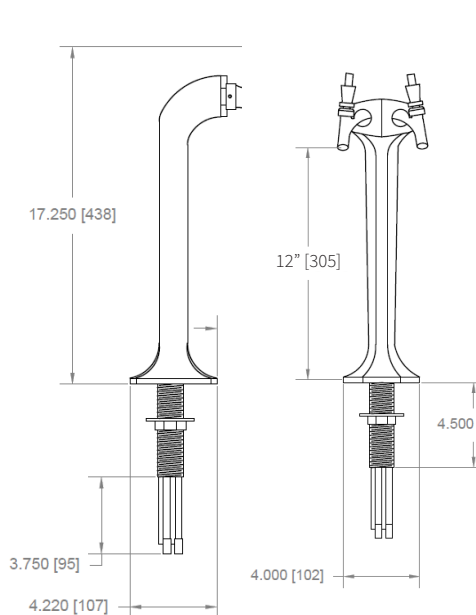

SI030812S Superseal elbow, loosen collet nut, push into SS tube and tighten collet nut.

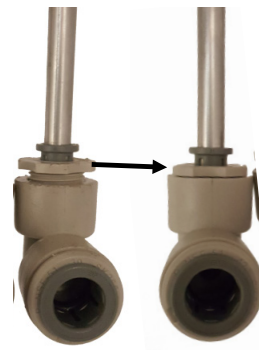

CR-4L3814 Trunkline Tower End Connections

Step 1: Locate the CR-4L3814 Trunkline. 5' will be included with the UCM install kit, unless a longer length was ordered. If a longer length is being used pull the line from the chiller to the tower, being careful not rip the pvc wrap and not to make any bends that kink the tubes. Leave enough length at both ends so connections can be made and the chiller can move for service. If installing 3-valve tower, the 3rd water line, ambient water, should be tee'd off the water filter outlet and fed over to the tower.



Trunkline: 3/4" foam insulation with a PVC exterior wrap.
Four 3/8" plastic barrier tubes, wrapped together.
Two-product tubes: blue striped & natural color.
Two re-circ tubes: red striped

Step 2: Cut back the insulation (or tubes) so 2.5"-3" of tubing is exposed.

Cut the two product tubes (blue striped and natural color ones) back 1.5", so the red striped tubes extend past them at least 1.5".

Cut the tubes square and remove burrs and sharp edges. Make sure the red striped tubes are cut to the same height.

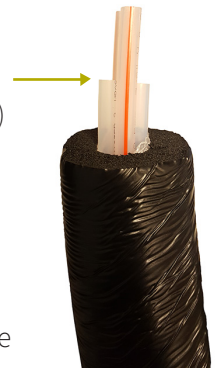

Step 3: Find the two white PP221212W plug in elbow fittings that come with the CBR Tower and connect them to the product tubes.

Find the grey PIUB12S u-bend fitting in the UCM install kit and connect it to the two re-circ tubes.

Use the red locking clips.

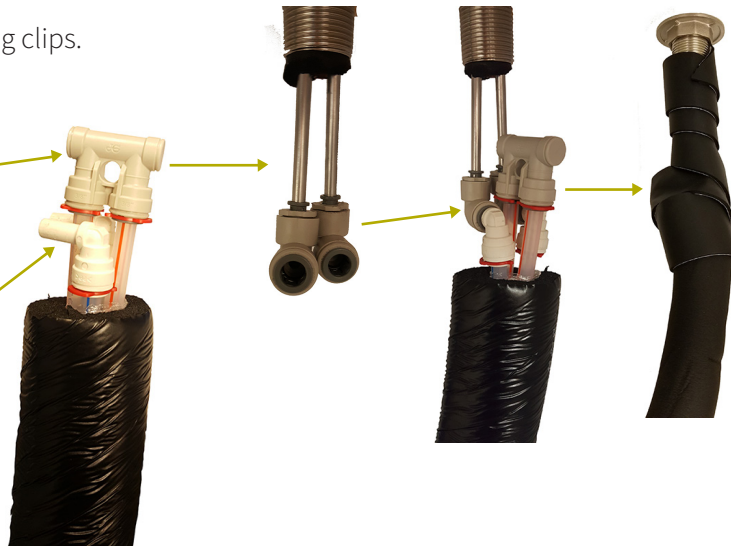

Step 4: Once assembled, connect the stem end of the plug in elbow fittings to the super seal fittings on the tower. Connect the blue striped tube to left faucet tube for sparkling water. Natural to still chilled water. If using a 3-valve tower, run a separate hose from the filter to the 3rd tube for ambient water. After testing the system for leaks, wrap all exposed hoses and fittings with the insulated tap found in the UCM install kit.



Mounting Faucets & Handles to Tower

Locate the faucet bodies, handles and wrench.

The faucet bodies attach to the shanks that are pre-attached to the tower and leak tested.

When attaching the faucet body to the shank, be sure the faucet is properly aligned before tightening it down. Adjusting the faucet angle when attached to the shank can result in loosening the shank to tower connection which can cause a leak.

Using the faucet wrench on the shank nut:

- Counter-clockwise tightens the shank nut to the faucet body.
- Clockwise loosens it for removal.



Push faucet onto the shank

Angle the faucet body vertically straight

Set the faucet position, push back to lock in

Pull shank nut to faucet and hand tighten

Tighten shank nut with faucet wrench



Once the faucet bodies are attached to the tower, thread the handles on to the them. Thread down until the position the handle with curve is facing you, if loose, tighten the black set nut up to the handle base to lock the handle in position. Apply the round sparkling and still water image stickers to the appropriate handles at the top of them.

Sparkling Water Flow Adjustment

Upon start up of the system, the CR-SSX0101-HEX Faucets used on the CBR-V1-SSX, CBR-V2-SSX, and CBR-V3-SSX dispensing towers will need the flow rate adjusted and set.



The faucets come equipped with a flow control valve on each of them to adjust and set the flow rate. The slower you can set the flow of sparkling water, the better the bubble profile.

1. This valve is located on the right side of each faucet. It is round with two flat sides.
2. Locate the 2.5mm Allen wrench (supplied with tower) and insert into allen head.
3. Flow is typically set based on the cup size. Sparkling water will retain more bubbles with a slower flow. Adjustments should be made while the faucet handle is held open and water is flowing, to visually see the flow setting. Also, it is advised to fill into the glass or

carafe you will typically be filling to judge the fill time and minimize splashing.

4. Once set, tighten the outer ring nut to help keep the flow set and prevent it from being loosened by hand. First hand tighten, then rotate an additional 1/4 turn clockwise with a wrench.
5. The valve may need to be adjusted periodically. Leave the supplied 2.5mm Allen wrench along with the red spanner wrench with the owner/operator.
6. Review with them the flow rate and how to adjust as well as the maintenance guide in the owners manual.

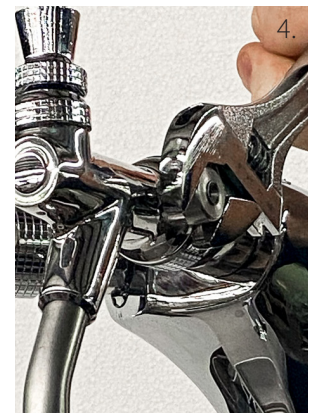

Installing the Water Filter System, Water Regulator, and Angle Stop Adaptor

Locate the water filter head assembly and filter cartridge. Then locate the 2 PI011223S 3/8" tube to 3/8" NPT fittings in the Install Kit. These are your inlet and outlet fittings for the water filter system. Wrap some Teflon tape around the threads of the NPT fitting, attach them to the two ends of the filter manifold.

Mount the filter manifold on the wall with at least 3" of clearance at the bottom of the filter so it can easily be removed and replaced.

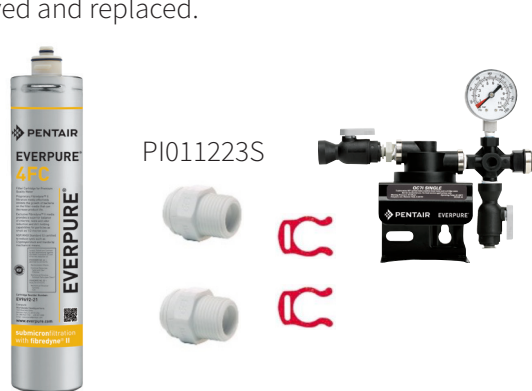

Locate the 183-150-NF 50 PSI Water Pressure Reducing Valve and two PI451214FS fittings from the UCM install kit. Attach the fittings to inlet and outlet of the WPRV.

Install reg with arrows pointing to the UCM unit.



Locate the PSEI6012U9 angle stop adaptor in the UCM Install Kit. Locate the angles stop water source feeding the system, remove the compression nut and ferule ring from it and replace with the PSEI6012U9 fitting.



Leak Block Sensor, LBS10JG:

1. Install the 3/8" fittings to the solenoid valve inlet and outlet ends. The thread of solenoid valve is 1/2" BSP male. Then connect a 3/8" OD tube from the angle stop to the inlet fitting on the solenoid valve (indicated by position of the arrow). Then connect a 3/8" OD tube from the outlet end of the solenoid to the water filtersystem that is feeding your Crysalli unit.
2. Put the 9V battery in the control unit and activate it by holding the check/reset button for 4 seconds (see operation instructions for more details).
3. Place the control unit next to your Crysalli unit, ideally between the filter system and chiller.



Install kit comes with 12' of the blue PE-12-EI tubing. Cut this to appropriate length for inlet and outlet needs. Your install kit may have some 1/4" braided hose in it. That hose is for the CO2 only. Do not use the braided hose on JG fittings.

Note: Crysalli does not provide external backflow preventers. Always reference local plumbing codes for the use requirement of a backflow preventer, as well as type and location within the system.

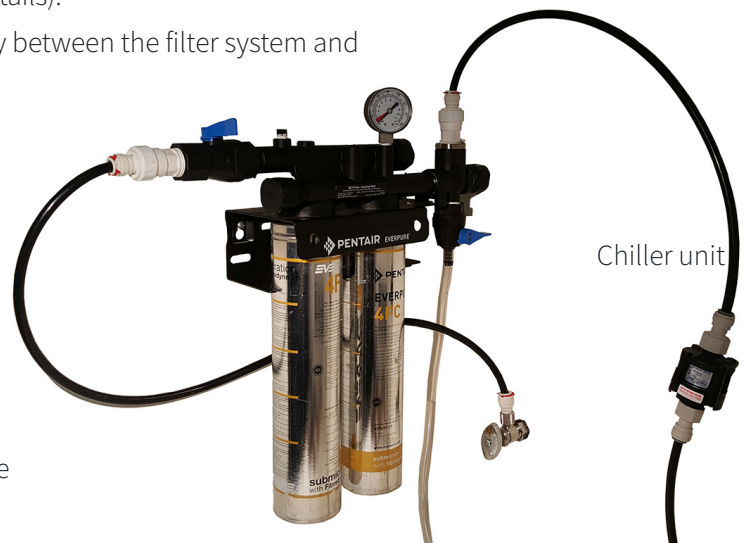

Place the unit in the cabinet space, with at least 4" of space behind it for clearance for the trunkline bundle, connections and chiller vents louvers on the side panels. Do not block any of the ventilated panels on the chiller.

Install CR-TFB1 Fan Box in cabinet at this time if using one.

Locate bundled Electrical cord, Water hose, CO2 hose and clear overflow hose coming from the bottom of the chiller and unwrap them (some units do not have clear overflow flow hose, and will drain to the drip pan).



1/4" Braided CO2 hose with stainless steel 1/4" flare nut end. Connects to CO2 Reg.
Hose marked "CO2"



Water inlet, CO2 inlet, overflow drain, and electrical



CR-TFB1 Optional accessory



1/4" Braided water inlet hose with 3/8" push-in stem fitting end. Fits into outlet end fitting of the 50 PSI water pressure reducer.
Hose marked "WATER"



9' Black electrical cord with NEMA 5-15 plug end should be plugged into a dedicated 120V outlet.

Note: GFI outlets are not recommended since they can trip when compressor cycles on.

If unit is supplied with a clear overflow vent hose, it should be routed to a floor sink if accessible and positioned per plumbing code.



Connecting the CR-4L14 Trunkline to the CP2000-R-UC-BH Chiller

Step 1: Locate the two 3/8" PP221212W and two 1/4" PP220808W Elbow fittings as well as two each of the red locking clips from the CPUC install kit. Connect these fittings to the trunkline hoses end first, then to the upper outlets on the back of the chiller.

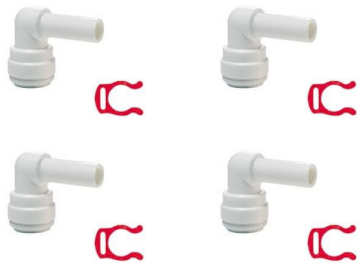

Step 2: If your trunkline will point downward, cut your white hose for sparkling water, 1" shorter than the other three. Then add fittings.



If your trunkline will point upward, leave the white hose long and cut the other three 1" shorter than it.



Step 3: The CP2000-R-UC-BH has four bulk head outlet connections to attach the trunkline to. Two horizontal 3/8" connections for the red striped re-circ lines and two 1/4" vertical connections for the product water lines. Still chilled water is marked "PLAIN WATER." Sparkling Wwter is marked "CARB WATER." With your trunkline prepared with the elbow fittings attached as described above you can now attach it to the chiller by pushing the fittings into the matching outlets. After you leak checked the fittings, wrap these fittings and hoses in the insulated tape to prevent sweating.

connections for the red striped re-circ lines and two 1/4" vertical connections for the product water lines. Still chilled water is marked "PLAIN WATER." Sparkling Wwter is marked "CARB WATER." With your trunkline prepared with the elbow fittings attached as described above you can now attach it to the chiller by pushing the fittings into the matching outlets. After you leak checked the fittings, wrap these fittings and hoses in the insulated tape to prevent sweating.

Downward pointing trunkline connection



Upward pointing trunkline connection



Step 4: Wrap all exposed hoses and fittings in insulated foam tape.



Connecting CO2 and Filling Water Bath

Step 1: The hose for the CO2 connection is 6' long, 1/4" braided hose with a 1/4" flare nut on the end extending out from the chiller near the water inlet. Route this hose to the location of the CO2 tank. If additional hose is required, the UCM Install Kit comes with an additional 8' of 1/4" braided hose*, a 1/4" barb union and 10.5 oetiker clamps to extend it.

***WARNING:** Do not use this extra 1/4" braided hose with John Guest fittings for the water inlet or water filter connection, it is not the correct OD or tube type to work with these fittings and will result in leaks.

If using dedicate CO2 tank, locate the CR-PC160 primary high pressure CO2 regulator. Unbox it and be careful to locate the 1/4" nylon washer taped to the packaging. Insert this washer into the flare nut on the end of the hose and thread it on to the 1/4" mpt flare on the CO2 reg. Locate paper washer with CO2 tank and thread CO2 reg to tank, making sure its tight.

For bulk CO2 tank use or shared CO2 systems, use the CR-S115 secondary high pressure CO2 regulator to regulate.



Step 2: Route the clear over flow water bath drain hose from the back of the unit to a floor sink or floor drain.

The water bath must be filled with water for the system to work and build an ice bank. This water is not used for consumption, it is only used to form an

ice bank around the refrigeration coils and chill the water flowing through the water cooling coils. Water will drain from the over flow hose upon initial start up as the ice bank forms. After that only periodic condensation may drip from the over flow hose.

Remove the lid of the chiller to expose the water bath area. Fill this area with water (preferably non-filtered) up to the white stand pipe, covering the carb tank, water coils and refrigeration coils.

Fill Bath with 2.5 gallons of Water or up to the white stand pipe, before turning on.

Water bath can be drained by pulling the white standpipe which will drain to the clear overflow hose or into the drip pan.



Water bath will freeze a 6 pound ice bank around refrigeration coils. Roughly 1/3 of the bath will be ice along the side while water around the chilling coils and carb tank stays liquid and is agitated.

CO2 Information

CO2 tanks can be sourced and refilled from local beverage CO2 companies (both bulk and/or tank) and welding supply companies.

On average, 1lb of CO2 will be used for every 5 gallons of sparkling water. A 20lb tank should carbonate 100 gallons (12,800oz or 378 liters) of sparkling water.



WARNING: CO2 can be dangerous. CO2 cylinders contain high pressure gas which can be hazardous if not handled properly. Follow all CO2 regulator instructions (found with CO2 regulator) and other handling instructions from the CO2 tank supplier.

CR-PC160 High Pressure CO2 Regulator 0-160 PSI

Attaches to 5-100lb CO2 tanks. Set at 75 PSI as a starting point.

Note: Low-pressure beer regulators 0-60 PSI will not work properly with Crysalli.

Fill level gauge: Volume of CO2 in tank. Tank is empty when needle is in the red zone or zero.

Output pressure gauge: Shows CO2 output pressure setting. Set to 75 PSI.

Threaded connection to CO2 tank.

1/4" Male flare connection to Crysalli chiller. Use nylon washer supplied with regulator in fitting.

Pressure adjustment screw and locking nut.





CP2000-R-UC-BH & CBR Tower Cleaning and Maintenance Recommendations

Daily:

- Wipe down the unit or draft tower, cleaning and drying all surfaces. (Use window cleaner on mirrored and chrome finishes).
- Clean and dry drain pan and drain grate. Check that water is draining, pour warm water down drain if necessary.
- Check over faucets for action and hand tighten any loosened handles or nuts on them to prevent leaks. The set nut holding the handle down will loosen with use. As can the shank nut.
- Check flow from faucet, loosen, readjust, and tighten flow control knob as needed.
- Check that flow, temperature and carbonation of water poured from the unit are consistent to average use.

Weekly:

- Clean the faucets by wiping them down. If there is any scale or slime submerge them in cleaners/sanitizer and use a brush on them.
- Check CO2 level at CO2 tank.

Monthly:

- Check for good water pressure at the water filter system by running water from flush valve on filter.
- Visually check pre-filter in clear bowl on water filter system (if applicable) to determine if it needs replacing. Use only EPC5-10 replacement pre-filter cartridge.

Quarterly:

- Check the water bath level, either top off or drain, clean and refill.

Semiannually:

- Change the water filters. Use only 4FC replacement filter cartridges.
- Drain water bath, clean and refill with new water.
- Remove and disassemble faucets for cleaning and inspection.

Annually:

- Inspect internal water bath components such as agitator/re-circ pump and blade, check valves for CO2 and water, and all hose connections.
- Flush and rinse system with food safe sanitizer (this work should be performed by a certified service tech).

Model Number:

Install Date:

Serial Number:

Installer/Service:

Scan for
warranty:

