

DP-CT

Countertop Mount Drain Pan

Specification Sheet



Scan for more resources!



Key Features

- Countertop mount drain pan design
- 10"W x 0.75"D x 6"H
- 0.5" Drain pipe

Product Overview

- Stainless steel construction
- For use and pairing with CBR-V1 and CBR-V2 models
- Removable drain grate for cleaning

Project:

Line Drawings

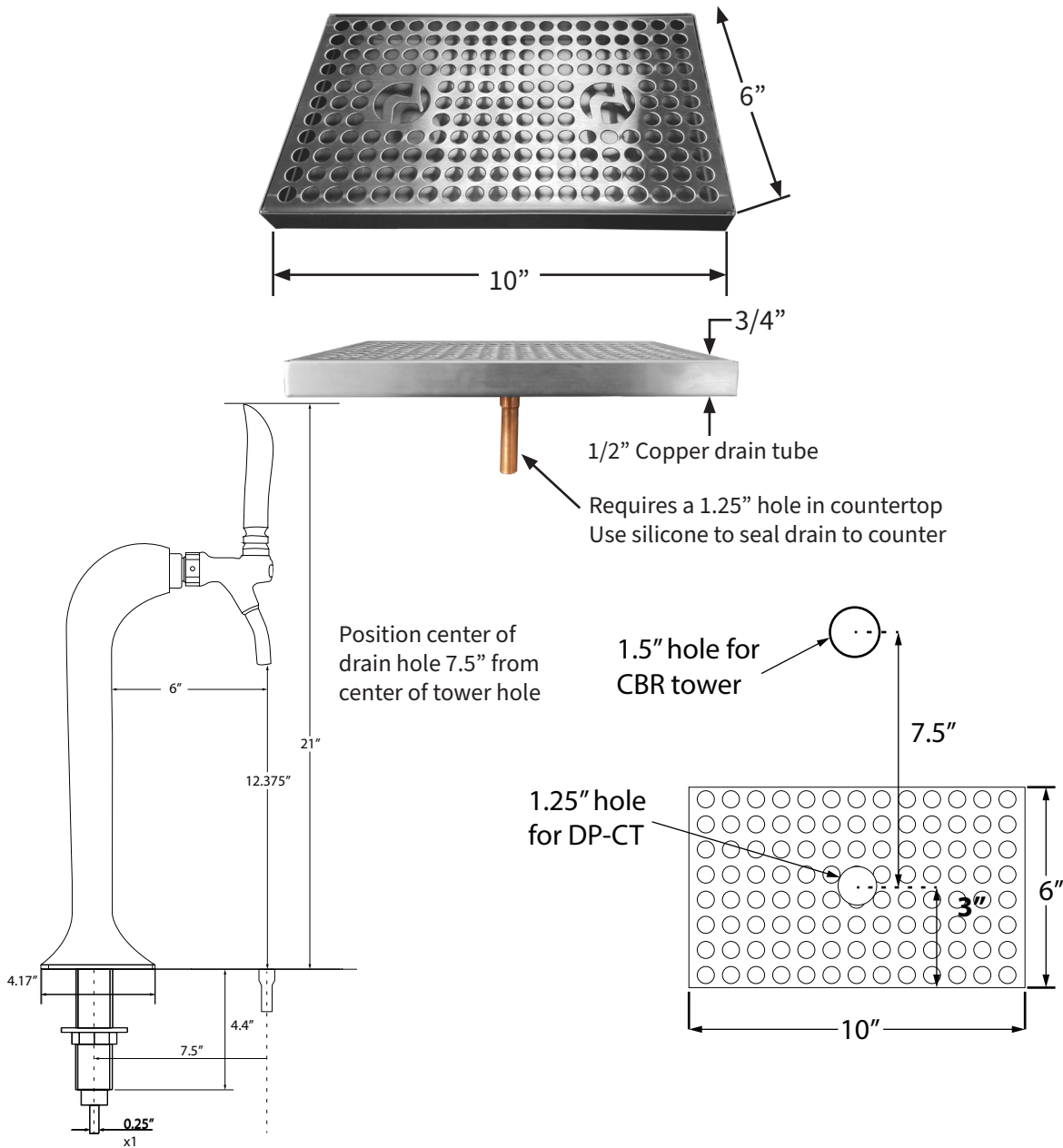

For use with

- CBR-V1C-SSX
- CBR-V1BLC-SSX
- CBR-V1C-SDLX
- CBR-V1BLC-SDLX



- CBR-V2C-SSX
- CBR-V2BLC-SSX
- CBR-V2C-SDLX
- CBR-V2BLC-SDLX

