

CP-JR-CT2FR-K

Low-Volume Compact Countertop Sparkling & Chilled Still Water Dispenser



Low-volume compact countertop beverage dispensing unit that provides sparkling water and chilled still water. Self-contained refrigeration with European design stainless steel exterior. Suitable for office, hotel suites, wineries, and residential.

Features

- Up to 40, 8oz drinks/hour (<45°F)
- Dual-water dispensing (sparkling + chilled still)
- Self-contained refrigeration
- Durable, 304 brushed stainless steel exterior
- Cup fill station with 8" clearance
- Installation kit included

Accessories

- Water filter replacement:
 - 2FC: Compact fibredyne cartridge for CP-JR models
 - 2FC-P: Compact fibredyne cartridge, 1.5 gpm 1,000 gal capacity. Certified PFOA/PFOs and lead-reduction filter, TOC and 0.5 micron
- Dispense levers:
 - CR-SDL-1: Single sanitary dispense lever that attaches to a self-closing faucet on unit. 1 per faucet. Great for self-service hands-free dispensing applications
- Wall brackets:
 - CR-CWB1: Single CO2 gas cylinder wall bracket



Complete installation kit (included with purchase of unit):

The unit comes standard with a filter system built on. Installation kit comes complete with primary CO2 regulator, 50 PSI water pressure reducer valve, leak block sensor, angle stop adapter, tubing and fittings.

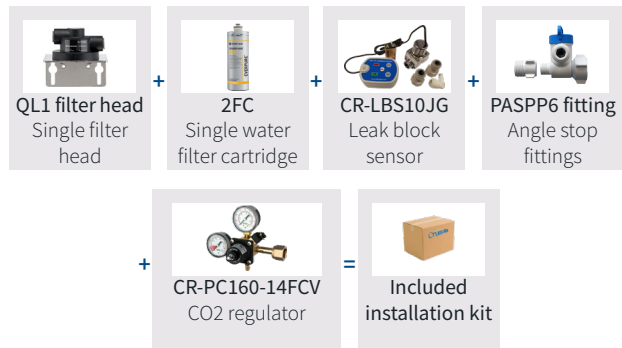

R290



CP-JR-CT2FR-K

Low-Volume Compact Countertop
Sparkling & Chilled Still Water Dispenser



Scan for more resources!

Line Drawings

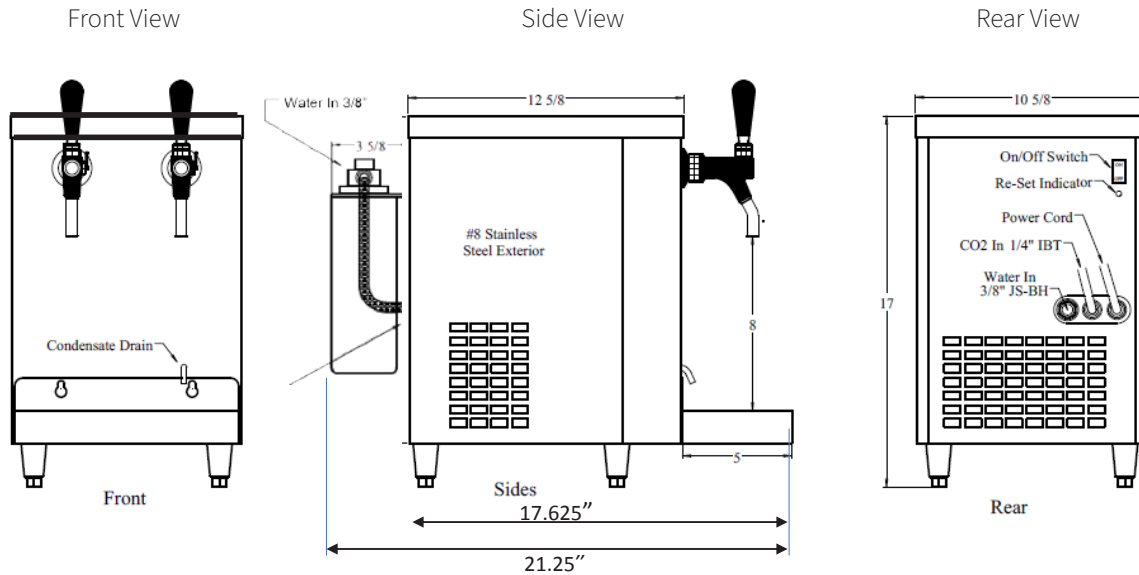

- 3/8" Water inlet push in fitting at back of machine
- 7' CO2 hose 1/4" flare fitting
- 9' Electrical cord NEMA 5-15
- 2.5" legs
- Pre-mounted water filter system with 2FC quick change cartridge
- Air intake on side panels, exhausts out rear
- Allow for 6" rear & side clearance for air flow
- Condensate drain into drip pan

Capacity	40, 8oz drinks/hour (<45°F)
Refrigerant	R290
Width	10.625"
Depth	21.25"
Height	17"
Cup fill clearance	8"
Compressor	1/9 H.P.
Carbonator	1 GPM

Operating temp	40°F-100°F
Electrical	120v - 2.9 Amps
Water bath	1 gal
Ice bank	3 lbs
Weight	80 lbs